

KOMATSU

Komatsu 875



Productive forwarder for both
final logging and late thinning



Modern Komatsu forwarders can trace their design origins back to models from the 1990s. The 840, for example, was upgraded with a 6-cylinder engine to become the 860. This period also heralded the birth of Komatsu's successful forwarder concept, which is based on ideas such as a low centre of gravity and an articulated joint facing the same direction as the rear frame. And thanks to this concept, Komatsu still offers the most stable forwarders on the market.



The Komatsu 875 is a powerful and versatile machine, equally effective for final logging and late thinning. A number of practical options provide an extremely flexible load area, and there are two different crane types to choose between. In addition to forwarding, the Komatsu 875 can be used for ground preparation. Like all Komatsu forwarders, the Komatsu 875 offers a good work environment with its spacious cab, ergonomic design and comfort-enhancing options such as Comfort Ride.

Designed with your profitability in mind

Komatsu forwarders are designed to be productive and profitable forestry companions. Here we present some of the advantages they offer to boost your business.



Flexible load area

Would you like a wider load area to carry more timber in a single load? Or hydraulic stakes that are easily lowered so that the crane can be kept lower to improve productivity and save fuel?

Every Komatsu forwarder has a flexible load area with many options to tailor it to your particular needs, enabling you to complete your forwarding work as efficiently and effectively as possible.

A crane that makes its mark

The crane is designed and fully optimised for use on a Komatsu forwarder, making it both reliable and productive.

Choose between different crane and grapple sizes for a crane solution tailored to your logging needs. The crane can also be equipped with smart options such as an integrated tilt column and effective lighting. Together with the powerful base machine, the Komatsu crane plays a key role in helping you to achieve your goals.

An engine that gets the job done

Every Komatsu machine has a powerful engine that combines raw strength with high torque at low engine speeds, making it ideal for terrain driving and helping to reduce fuel consumption.

Each engine also has a sturdy build to minimise maintenance and repair costs.



The Komatsu concept for excellent stability

Komatsu forwarders get their excellent stability from the Komatsu concept's smart design solutions.

A stable machine offers you a work environment in which you feel safer and more relaxed while on the job, enabling you to maintain higher productivity and high energy levels throughout the day.

Off-road manoeuvrability

Manoeuvring in the forest demands a machine with good off-road handling and a powerful transmission.

High portal bogies ensure good ground clearance on all Komatsu forwarders while the intelligent transmission optimises its operation according to the machine's load, current ground conditions and the power and torque produced by the diesel engine. The result is a truly agile forwarder, even in demanding terrain.



You can read more about our stable Komatsu concept at: www.komatsuforest.com

A cab to long for

Your work environment plays a central role in your wellbeing. Here you can read more about how the ergonomics, thoughtful designs and easy servicing of a Komatsu make your working day that much better.

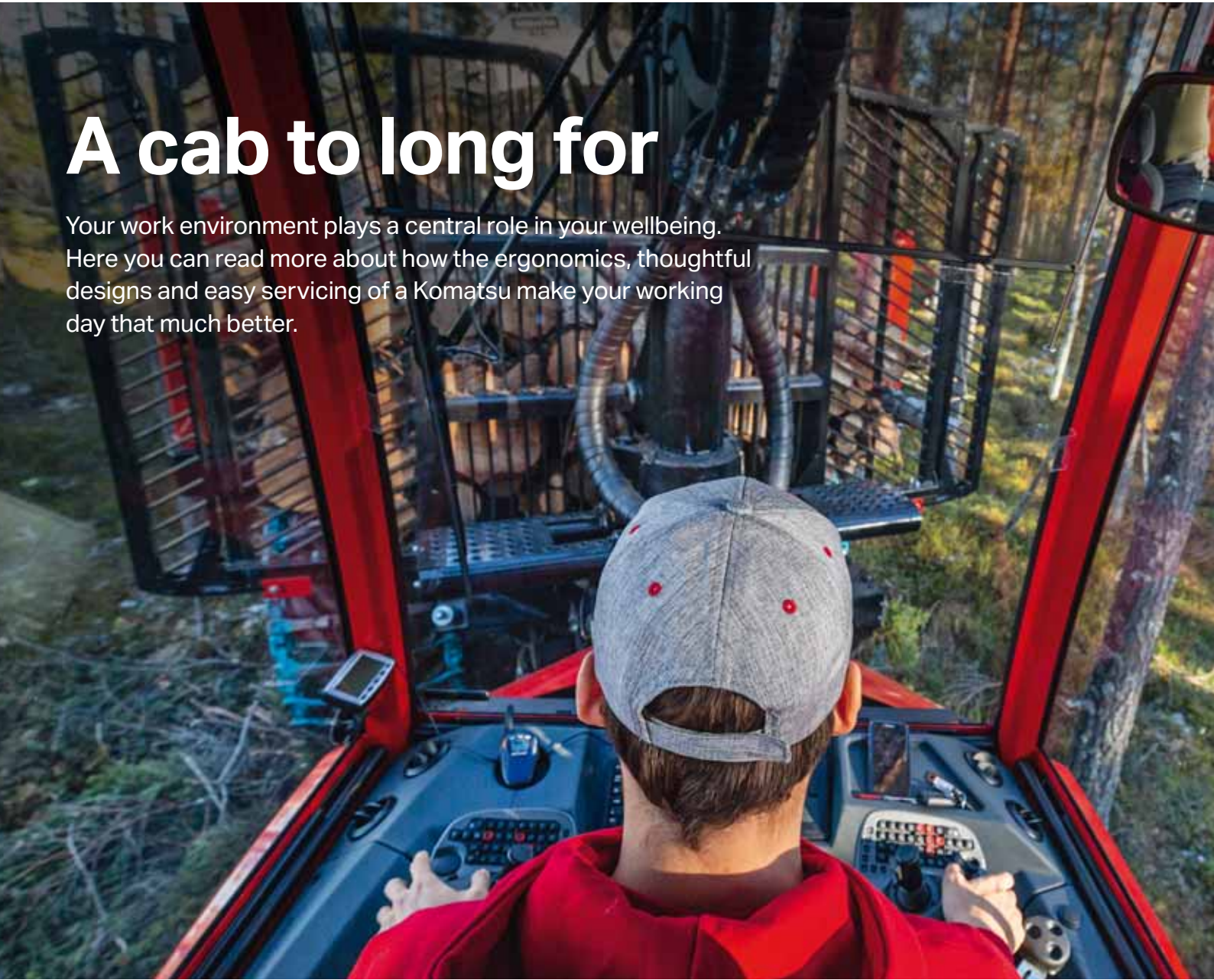

Good visibility in all directions

The cab is your work environment and a place we want you to enjoy. This is why our forwarder cabs are spacious and quiet with good visibility in all directions. The gate has a well-considered design that easily allows you to see through the slats. It also has a matte finish to minimise distracting reflections.

Interior lighting that does what it should

The cab has practical lighting, along with both the ceiling and the floor, so that you can easily find what you are looking for. There is also an optional reading lamp with a flexible arm. Night mode switches all the cab lights to a faint red glow, making things easier on the eyes when it is dark outside.

A comfortable driving experience

The driver's seat provides good back support, is electrically adjustable and even offers adjustable legroom. It has a built-in heater and can also be equipped with ventilation for a more comfortable work environment. If you would like to take your work environment to the next level, we recommend Comfort Ride, our hydraulic cab suspension, which you can read more about on the options page.



Ergonomic hand controllers, pedals and buttons

All hand controllers and pedals boast ergonomic designs and are close to hand in the cab. All buttons are illuminated so that you can easily navigate the controls in the dark, and many of their functions can be programmed for a highly personalised keypad set-up. The forwarder is easily manoeuvred using an electric mini steering wheel rather than the Orbital steering wheel found on older models.



Comforts to see you through the working day

Enjoy a premium-quality interior with plenty of storage spaces in the practically designed panels. The cab also boasts an optional food box heater and cooler, enabling you to quickly prepare your meal when it is time for a well-deserved break. The cab climate is kept comfortable by an ACC system that automatically regulates the airflow and temperature to match your preferences. Moreover, the cab can be fitted with an optional microfilter for even cleaner air.



Easily serviced

Machine maintenance should be easy, especially the measures that need to be conducted regularly. This is why Komatsu forwarders have a number of smart solutions to make life easier for operators. The electrically operated hood can be opened 90 degrees for easy access, and the entire cab can be tilted electrically. Moreover, the optional filling pumps make light work of topping up with hydraulic oil and diesel.

Our forwarders can be equipped with practical service lighting in advantageous places for easy servicing even in the dark. These are just a few of the solutions designed to make your working day that much easier.



For forestry today as well as tomorrow

As a machine manufacturer, we consider it important to strive to reduce our environmental impact, whether within production or in terms of machines with minimal forest impact. There are many challenges, but we are working hard to develop the solutions of the future while continually identifying opportunities for improvement, right down to the smallest details.

Production with the environment in mind

Autumn 2021 saw the start of production at our new factory. Since we have spent many years making our production more environmentally friendly, it was a given to keep climate impact in mind when building our new factory. Atop its roof is a solar farm comprised of 7,000 solar panels, covering an area of almost 19,000 m² or 3½ football pitches. The factory has been built using modern techniques to reduce energy consumption while geothermal energy provides most of the heating. We are proud of our new factory and the environmental progress it represents, and efforts to further reduce our environmental footprint will continue.

Low emissions and low fuel consumption

When operating a Komatsu forwarder, you can rest assured that it complies with strict NO_x and particulate emissions legislation. Moreover, we have worked hard to make our machines as fuel efficient as possible while still being able to offer exceptional performance. Every litre of diesel saved counts! To further reduce emissions, you can choose to use HVO, a greener fuel compatible with all our engines.

Options with the climate in mind

We have several options that help reduce a machine's carbon emissions by various means. Our smart SpeedShift gearbox automatically shifts up as your speed increases, ensuring optimal working revs at all times and thereby reducing emissions and lowering fuel consumption. Our Smart Crane and SmartFlow crane options both help optimise crane operation and thereby reduce emissions, with tests showing that both functions help reduce the machine's fuel consumption.





Smarter ways of getting timber to the roadside

As an operator, you too have ample opportunity to make a difference with smart decisions. Our MaxiFleet technology can offer knowledge and insights to help you along the way, with smart map layers providing valuable information about ground and weather conditions as well as the location of the timber. All this makes it easier for you to plan your driving and choose the best route to reduce both distances and ground damage.



[Read more about MaxiFleet > Forestry Solutions brochure](#)

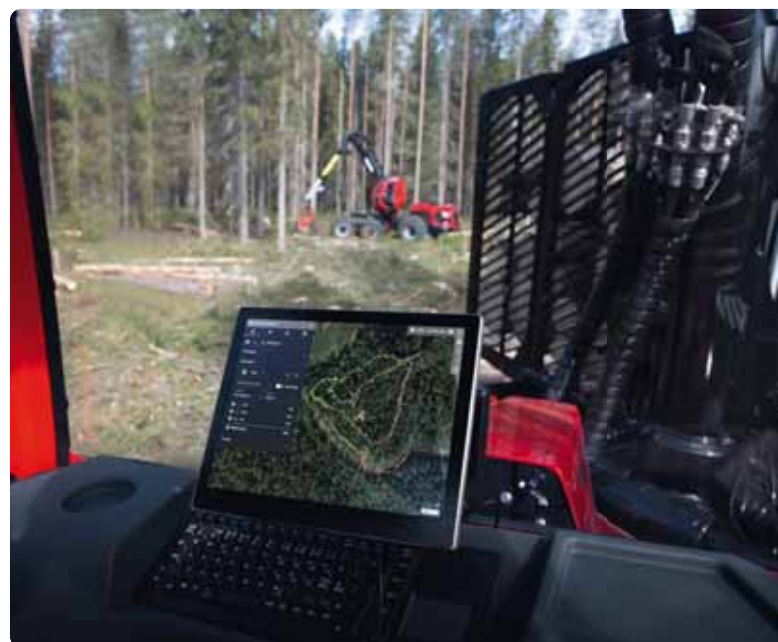

The choice is yours

To ensure that you have the best possible workplace, we have developed options that help you to maintain not only high productivity, but also an ergonomic and comfortable work environment. Everything for your wellbeing – both now and after many years on the job.



Tailor your workplace

The cab of a Komatsu forwarder has an ergonomic design with many added conveniences. We even have a wide range of extra equipment that enables you to tailor your workplace to suit your personal preferences. Optional extras include:

- **KCC advanced hand controllers with five extra programmable buttons**
- **Sunshades**
- **Radio with Bluetooth and hands-free support**
- **Ventilated seat**
- **Food box heater**
- **Cooler**
- **Side wipers**
- **Allergy filter 3 μ**
- **An additional floor mat that is easily removed for cleaning**
- **Seat column with 220° working range that can be locked in any position**
- **Interior ceiling and floor lighting, reading lamp on flexible arm**
- **Remote control key**
- **MediaZone**
- **Modem**
- **Extra display, front**
- **Touchscreen**



An illuminating option

Good visibility is a prerequisite not only for doing a good job, but also for working long hours without tiring. Our machines are equipped with effective lighting as standard, but we even offer a number of optional lamps for additional illumination.



Crane tilt

(Crane tilt is available for the 130F crane)

The crane tilt option enables you to work as though on flat ground even when on a slope by compensating for the incline. This allows the machine to offer flat-ground performance on up to 22 degrees inclines.



SpeedShift

With SpeedShift, your forwarder automatically shifts up as you increase speed. In addition to giving operators one less thing to think about, SpeedShift has the advantage of maintaining optimal engine speed, which saves fuel and can even increase productivity. SpeedShift is most advantageous during transport driving.



Options



Comfort Ride

Comfort Ride is our hydraulic cab suspension with a 4-point design that effectively damps jolts and vibrations caused by the terrain, tracks and crane. With the latest generation of Comfort Ride, you can also adjust the lateral rigidity, enabling you to find your own sweet spot. Another advantage is the automatic levelling, which keeps the cab upright on inclines of up to 6 degrees while

stationary or at low speed, simplifying loading and unloading.

There is already a function to raise the cab to its topmost position for the best possible view when unloading. However, with Komatsu's latest Comfort Ride, this function works even when moving slowly so that you can work as efficiently and ergonomically as possible.

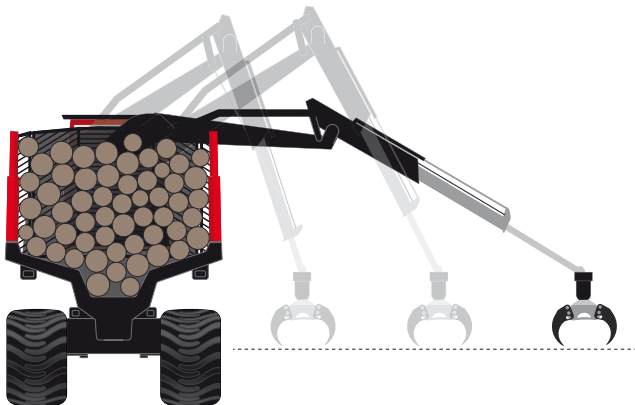

Smart Crane/SmartFlow

Smart Crane is a crane tip control solution for operation smooth and exact. With just three joystick movements, the operator can quickly get the grapple exactly where they want it. The telescopic boom extension is controlled automatically, meaning one less thing for the operator to think about. Smart Crane offers advantages such as less fatigued operators, greater productivity and a flatter learning curve for new operators.

The technology found in Smart Crane builds on SmartFlow, our intelligent crane control. With its active crane damping, it ensures impressive responsiveness – SmartFlow has been described as making the crane an extension of your arm. Smart Crane includes the SmartFlow option, although it is also available separately.



Creating value together

The forestry industry supplies valuable materials that benefit us all. From construction materials for homes and fences through packaging for groceries and parcels to the pages of our kids' bedtime story books and energy to heat our homes.

As a raw material, wood also plays an important role in transitioning from fossil-based materials to renewable alternatives. And it is your hard work that makes all this possible, so thank you!

We want to be a partner you can trust when creating these values. Komatsu has stood by your side for an entire century, offering unique quality, peace of mind, knowledge and support. Our way of working is distinguished by our partnership with you, our customers, from innovation to manufacturing. Together, we create the solutions required to achieve a sustainable future for people, businesses and our planet.



A load area tailored to your needs

Every Komatsu forwarder has a load area characterised by flexibility and multiple options. By combining various options, you can create the perfect load area for your type of work and one that helps to increase your productivity.



FlexBunk – a world of flexibility

FlexBunk is the name of our flexible bunks that can be tailored to your needs. Fixed stakes and standard-width bunks are included as standard, but you can combine many options to create a more customised load area.

Hydraulic height-adjustable stakes

Lower stakes enable you to keep the crane lower, which in turn means faster crane operation and improved fuel economy.

A wider load area

You can also widen the load area with the optional widening kit, which includes widening sleeves attached to the bunks. The crane can then extend and retract these sleeves as necessary, and we even have an option to widen the load area manually.



Hydraulically operated gate (option)



Group assortments with separating supports (option)



FlexGate

FlexGate is our ingenious standard gate that improves visibility and flexes out of the way if struck by the crane, thereby simplifying loading and minimising the risk of damage to the machine. We also offer a range of widening wings for FlexGate.



LoadFlex – A premium-class load area

LoadFlex is a high-grade option comprising our smartly designed LoadFlex bunks for optimal flexibility and load capacity.

The LoadFlex option enables you to adjust the width of your forwarder's load area to match the needs of each forwarding job. The forwarder's crane can easily adjust the pivoted bunks, whether set to narrow, medium or wide.

With an extra-wide load area, the forwarder gains an extremely low centre of gravity, increasing stability and providing a more comfortable off-road experience. LoadFlex includes hydraulic height-adjustable stakes for more efficient crane operation and lowers fuel consumption.

Technical specifications



Dimensions

eight-wheeler with shortest rear frame option and 710 mm tyres

	130F crane	145F crane
A Width	2,980 mm	2,980 mm
B Length, total	10,360 mm	10,360 mm
C Length, front axle to articulated joint	1,900 mm	1,900 mm
D Length, articulated joint to rear axle	3,480 mm	3,480 mm
E Transport height, with hoses and tyre compression	130F: 3,880 mm	145F: 3,930 mm
F Ground clearance, at steering coupling	710 mm	710 mm

NB: Stated dimensions are nominal and may vary depending on production tolerances and optional equipment.

Weight

Weight from	6WD: 17,800 kg, 8WD: 20,100 kg
-------------	--------------------------------

Engine

	6-cylinder diesel engine with turbo and intercooler. Conforms to the requirements of EU Stage V (Europe), Tier 4F (North America), MAR-1 (Brazil) and Stage II (other countries).
Engine type	Stage V: 74 LFTN-D5, Tier 4F: 74 LFTN-D4, MAR-1: 74 CW3, Stage II: 74 LFEN-A2
Engine displacement	7.4 l
Power, max.	Stage V, Tier 4F and Stage II: 190 kW DIN at 1,850 rpm, MAR-1: 185 kW DIN at 1,900 rpm
Torque	Stage V, Tier 4F and Stage II: 1,130 Nm at 1,500 rpm, MAR-1: 1,000 Nm at 1,500 rpm
Fuel tank	220 l
AdBlue® tank	21.5 l (filled volume)

Transmission

	Computer-controlled hydrostatic mechanical transmission. 6/8-wheel drive. Transfer gearbox with 2 positions (high and low). Disengageable rear drive. Differential locks front and rear.
Driving speed	0–approx. 23 km/h
Tractive force	214 kN
Examples of other equipment	SpeedShift, Overspeed protection.

Frame/Axles

	Several rear frame options. Frame with smooth V-shaped bottom made of high-strength steel. Sturdy balanced portal bogie. Damping bogie tops. Towing points front and rear.
Examples of other equipment	Front blade.

Hydraulic system

	Single-circuit load-sensing with variable piston pump.
Flow	360 l/min at 2,000 rpm
Hydraulic oil tank	150 l
Other	Pressure filter for hydrostatic circuit. Dual return oil filters for hydrostat and working hydraulics. Hydraulic oil level alarm.

Brake system

	Fully hydraulic multi-disc brakes. Hydraulic accumulator charging valve.
Driving brake/ Working brake	Multi-disc brakes in oil bath. Automatically engaged when working.
Parking brake	Spring-action brake with electro-hydraulic control. Emergency brake.
Braking performance	Conforms to ISO 11169 and VVFS 2003:17.

Cab/Ergonomics

	Tested in accordance with applicable ISO standard. Spacious and bright with very good visibility. Thermal and acoustic insulation.
Seat	Several alternative seat options. Ergonomic design with headrest, armrests, hand controllers and lap belt. Depending on seat selection, different options are available for individual adjustment of the seat cushion, backrest and lumbar support. Seat column with 0–180° working range.
Windows	Polycarbonate windows throughout.
Heating/ventilation	Fully automatic heating and cooling unit, ACC. Filtered intake air.
Noise level	As per ISO standard
Vibrations	As per ISO standard
Other	Windscreen wipers and washers on windscreen and rear window. Fire extinguisher, 2 kg (standard in EEA countries in compliance with applicable EU Directive).
Examples of other equipment	Komatsu Comfort Ride (cab suspension). Radio with Bluetooth and hands-free support. Seat column with 220° working range. MediaZone.





Load area

Gross load	16,000 kg
Load area	4.5-6.4 m ² depending on options and market.
Load bunks	Mounted on runners, movable.
Load gate	Komatsu FlexGate, hydraulically flexible full-height gate, fixed or hydraulically adjustable model.
Examples of other equipment	Bunk widening, hydraulic height-adjustable stakes, first bunk connected to gate, separating supports, LoadFlex.

Crane and grapple

Crane	130F	145F
Reach	8.0/ 10.0 m	8.5/ 10.0 m
Lifting torque, gross	127 kNm	145 kNm
Slewing torque, gross	28.7 kNm	38.0 kNm
Rotator	G121/GT151	
Grapple	Komatsu G28	Komatsu G36
Crane tip	ProTec	
Examples of other equipment	Alternative grapple and rotator models. ProTec Scale crane scale. SmartFlow.	

Steering

	Hydraulic articulated steering with dual double-acting hydraulic cylinders.
Joystick steering	Load-sensing (LS) proportional steering with steering rocker switch.
Electric steering	Finger-controlled mini steering wheel on right armrest.
Steering angle	±42°

Electrical system

Voltage	24 V
Battery capacity	2 x 180 Ah
Alternator	2 x 100 A

Lighting

Working lights	10 lights on cab and 2 lights on crane (halogen)
Driving lights	2 front lamps (halogen)
Service lighting	LED lights in service compartments
Examples of other equipment	Working lights (LED), variations of extra working lights (LED), driving lights on rear bunk and separate mount by tow bar (LED). Driving lights, front (LED).



Examples of other equipment

- Sprinkler system. Fully automatic water-based fire extinguishing. Conforms to SBF 127.
- Hand-held fire extinguishers. 2 x 6 kg ABE-3. Powder extinguishers.
- Diesel heater. 9.1 kW incl. timer. Hydraulic oil heater.
- Biodegradable hydraulic oil.
- Extra water separator (diesel).
- Tracks, chains.
- Toolbox with tools (heated in engine compartment).
- Central lubrication.
- Reversing camera, rear (standard in EEA countries in compliance with applicable EU Directive).
- Reversing camera, front.
- Vacuum pump.
- Wear guard and chain guard for bogie casings.
- Service ladder at hydraulic tank (standard in EEA countries in compliance with applicable EU Directive).
- Front guard.
- Remote control for central locking (Europe only).

Notes

Standard and extra equipment are market-dependent and vary between countries. This product brochure describes functions that are in some cases optional. Check with your dealer as to what is standard or optional. Weights are based on the equipment specified in the basic specification. Specifications and designs are subject to alteration without prior notice.



MaxiXT control and information system

- Fully integrated machine control system, CAN-based with crane, engine and transmission intelligence for optimum performance and fuel consumption.
- Production follow-up system for forwarders. Registers timber deliveries (assortments) and roadside wood pile locations. Delivery selection using hand controller buttons.
- Optional ProTec Scale crane scale system. Automatic and highly accurate weighing. Compact scale link with hose routing through the link.
- Easy-to-use operator interface. High-performance PC with Windows operating system, SSD hard drive, touchscreen selection and data backup function. Antivirus software.
- Comfort Controls. Ergonomic joysticks of various types with extensive functionality.



KOMATSU

komatsuforest.com